

The Grundfos Home Boost

A plug-and-pump solution for domestic cold water boosting.



The Home Boost is a robust, self-contained cold-water booster set, specifically designed for domestic properties where the existing mains water supply can be insufficient to meet demand requirements. It's an ideal solution for domestic installations where space is at a premium. The unit holds a 340 litre tank capacity and comes fitted with a Grundfos SBA submersible pump.

The integrated controller comes complete with motor and dry run protection, and provides a silent alternative to surface-mounted pumps. The Home Boost ensures high efficiency, sustained performance, a long working life and quiet operation.

Installation is simple, and requires a connection to the mains cold water supply, discharge pipe, overflow pipe and electrical connections.

The unit should be sited on a solid flat surface, in a dry, well ventilated, frost-free location suitable to support the weight of the unit filled with water.



INTEGRATED
BYELAW 30 KIT

INTEGRATED
CONTROLLER

2 YEAR
WARRANTY

INTEGRATED PUMP - SBA 3-35 M

Designed for pumping clean domestic water, the SBA 3-35 is fully integrated into the unit. With built-in thermal protection, the pump will automatically stop if overheated, and return to operation once it reaches normal temperature.



SBA 3-35 M PERFORMANCE CURVE

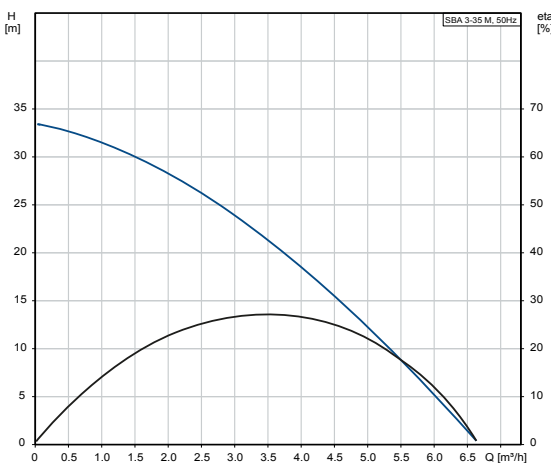

FEATURES

- Comes completely fitted with Byelaw 30 kit
- Integrated 340 litre storage tank
- Integrated controller with dry-run protection
- Electronically on/off controlled
- Packaged set ready for installation
- Dry run protection, thermal protection and frost prevention
- WRAS Approved Components
- Robust high torque start-up and auto de-blocking function
- Firmware upgrades ensuring that the pump is always up to date and prepared for future digital offerings
- Pump-venting process after which the pump automatically returns to its initial settings

SERVICE CONNECTIONS

- Mains cold water: ½" BSPM
- Overflow: 22mm
- Discharge: 22mm
- Mains power cable: 15m x 1.5mm² 3 core

BYELAW 30 KIT

The Home Boost comes complete with an integrated Byelaw 30 kit. The built-in Byelaw 30 kit protects the water from contamination.

ACCESSORIES

We offer a full range of insulation jackets and drip trays for the Home Boost.



340L HORIZONTAL DIMENSIONS (mm)

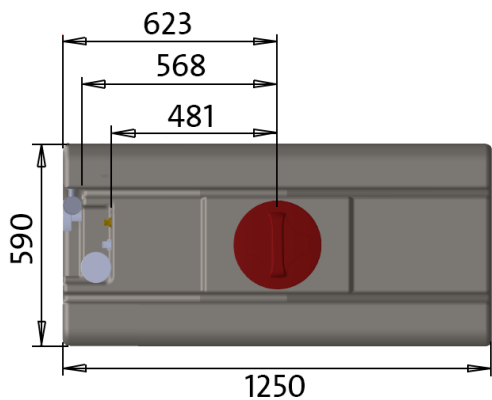

Top View

Pump holder insert added for horizontal orientation

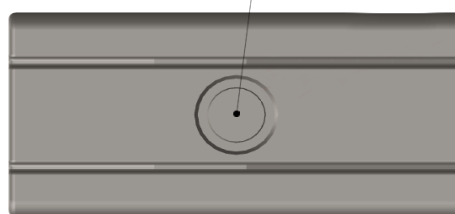

Bottom View

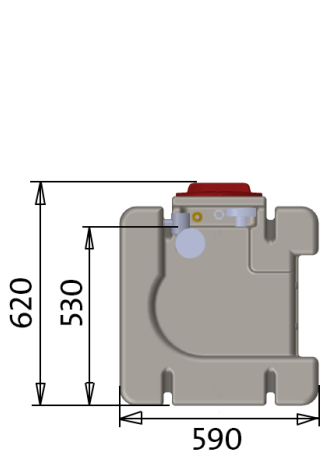

Front View

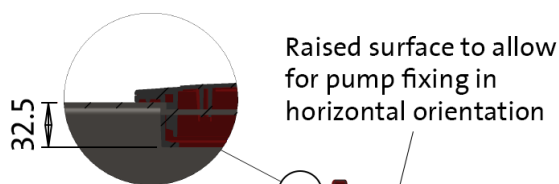

Raised surface to allow for pump fixing in horizontal orientation



Side View Section

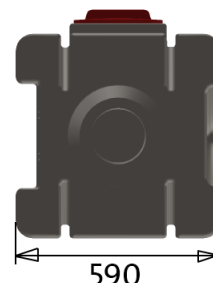

Back View